

2006 .

14-1-5254-2006

(14-1-5254-94)

Директор НИИЖБ-
филиала ФГУП «НИИ «Строительство»

Главный инженер
ОАО «Западно-Сибирский
металлургический комбинат»

А.С. Семченков
2006 г.

Т.Р. Галиуллин
11 2006 г.

На 19 стр.

Смагач

Москва, 2006

Центральный научно-исследовательский институт
черной металлургии
ТЕХНИЧЕСКИЕ УСЛОВИЯ
ЗАРЕГИСТРИРОВАНЫ
11 декабря 2006

16-40 ,

« -

»

1

:

1.1

:

(-

1).

1.2

:

(2).

1.3

:

(2).

52544

7.

2

2.1

:

500 , 400 -

500 , 400 -

:

;

-

-

-

500, 400 -

500 400 / 2.

2.2

1

1.

1 -

1

d _H ,	F _H ,	1	
		,	%
6,0	28,3	0,222	±8
8,0	50,3	0,395	
10,0	78,5	0,616	
[12,0	113,1	0,888	±5
14,0	153,9	1,208	
16,0	201,1	1,578	
18,0	254,5	1,998	
20,0	314,2	2,466	
22,0	380,1	2,984	
25,0	490,9	3,853	±4
28,0	615,8	4,834	
32,0	804,2	6,313	
36,0	1017,9	7,990	
40,0	1256,6	9,865	
45,0	1590,4	12,485	
50,0	1963,5	15,413	±3
55,0	2375,8	18,650	
60,0	2827,4	22,195	
-	1	7,85 / 3.	

2.2.1

52544.

2.3

52544

7:

$$t = (0,4-1,0) d_{H_i}$$

$$h = (0,065-0,1) d_{H_i}$$

$$Ee_j = 0,27 i d_{H_i}$$

f_R

52544

7.

2.3.1

1

2.



Рисунок 1 – Арматурный прокат серповидного периодического профиля



Рисунок 2 – Арматурный прокат винтового профиля

2 -

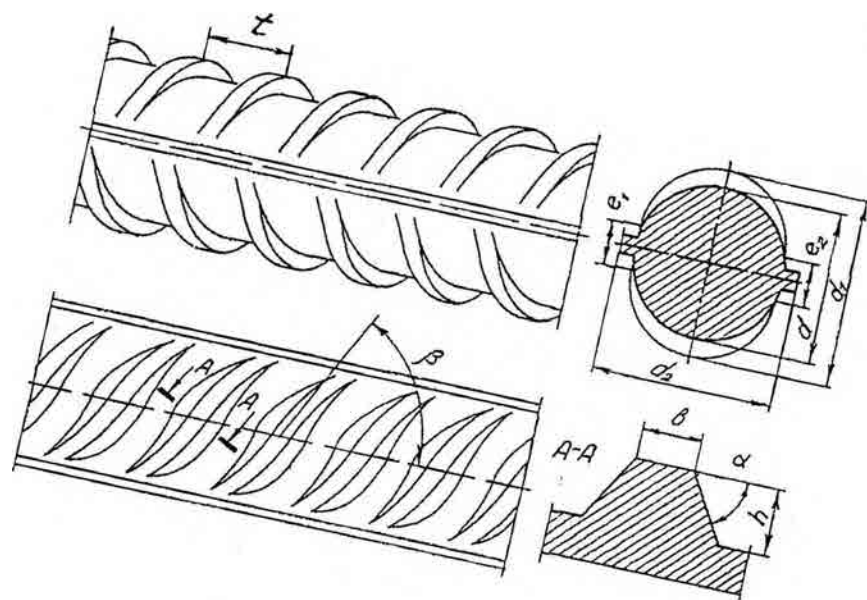
d _{Hl}	d,	h,	d-i, d ₂ ,		t,		ei, e ₂ ,	fR,	d ₁ -d ₂ ,						
			()	()		%			()	()					
6	5,8	0,4	7,0	±0,8		4	±15	0,6	1,9	45	60	35	0,039	1,6	1,2
8	7,7	0,6	9,3	±0,8	±0,6	5	±15	0,8	2,5	45	60	35	0,045	1,6	1,2
10	9,5	0,8	11,5			6		1,0	3,1				0,052		
12	11,3	1,0	13,7	±1,1		7		1,2	3,8				0,056	2,2	
14	13,3	1,1	15,9			8		1,4	4,4						
16	15,2	1,2	18,0			9		1,6	5,0						
18	17,1	1,3	20,1	±1,5	±0,8	10	±15	1,8	5,6	45	60	35	0,056	3,0	1,6
20	19,1	1,4	22,3			11		2,0	6,3						
22	21,1	1,5	24,5			12		2,2	6,9						
25	24,1	1,7	27,7			13		2,5	7,9						
28	27,0	1,9	31,0			15		2,8	8,8						
32	30,7	2,2	35,1	±2,0	±1,2	16	±15	3,2	10,0	45	60	35	0,056	4,0	2,4
36	34,5	2,4	39,5			18		3,6	11,3						
40	38,4	2,7	43,8			20		4,0	12,5						
45	43,4	2,9	50,0	±2,5	±1,6	21	±15	4,5	14,2	45	60	35	0,056	5,0	3,2
50	48,2	3,1	55,0			22		5,0	15,6						
55	53,0	3,3	60,0			24		5,5	17,3						
60	57,8	3,5	65,5			25		6,0	18,8						

2.3.2

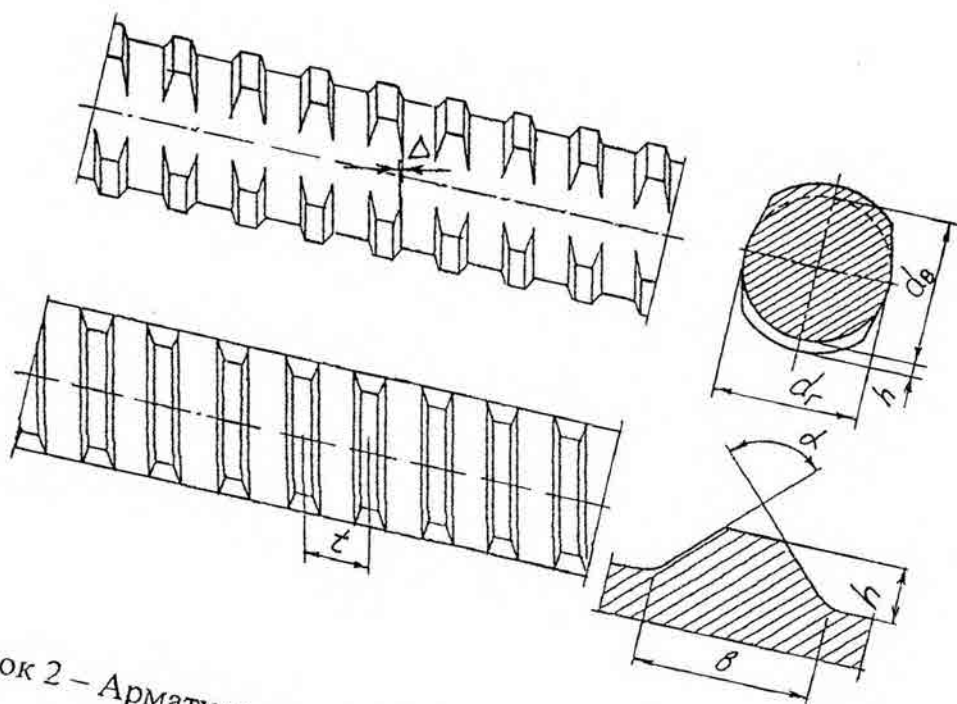
:
- h;
- t;
- (ei+e₂);
- d, -d₂|-
-
- ()
-)

fR

2.4

2.4.1

2 3.

: d_B, d_r, h, t, b A.

2.4.2

3

±15%,

2.4.3

15,0 26,5

1.

15,0 26,5

1

2

4.

3 -

d _H	d _B		d		h		t			b	
	-	-	-	-	-	-	-	-			
16	15,5	±0,35	15,2	±0,40	1,4	-0,40 -0,10	9,0	±0,2	±0,2	4,0	50
18	17,4		17,1		1,5	-0,50 -0,15	10,0			4,5	
20	19,3		19,0		1,6		11,0			5,0	
22	21,3	21,0	1,7	12,0	5,5						
25	24,3	±0,40	23,9	±0,50	1,8	14,0	±0,2	6,5			
28	27,2		26,8		2,0	15,0	7,0				
32	31,1		30,7		2,2	17,0	±0,3	8,0			
36	34,8		34,4		2,5	18,0		9,0			
40	38,6		38,2		3,0	20,0		10,0	45		

4 -

15 26,5

d _H	F _h , mm ²	1	%	d _B		d _r		h	t			b	
				-	-	-	-		-	-			
				-	-	-	-	-	-	-	-	-	-
15	177	1,39	-5,0 -6,0	14,8	±0,3	14,6	±0,3	1,2	10,0	±0,2	±0,2	4,0	50 i
26,5	551	4.48	+3,0 -2,0	26,4		25,9	±0,5	1,7	13,0	±0,3		6,2	

2.5

(), (),

36 , 500 :

- - 36- 500 14-1-5254-2006.

3

3.1

3.2

5.

5 -

()				
	500	500	400	400
	6-60	16-40	6-60	16-40
1	2.2			
f_R	2.3			
(.),	500		400	
/ 2,	600		500	
(/ ,2),	1,1			
6 ₅ %,	14		16	
5 ₀ %,	2			
	3.3			
=0,6- (,2) 2-10 ⁶ ,	150			
/ 2 / 2	3.5			

3.3

-

3d_H;
90°

:
160°

20°

6.

6 -

d _H	
12	5d _H
.12 16	6d _H
.16 25	8d _H
.25 60	10d _H

3.4

52544

7.

7 -

	, %,							- - , > %i
	-	-	-	-				
-	0,22	0,90	1,60	0,050	0,050	0,012	0,50	0,50
	0,24	0,95	1,70	0,055	0,055	0,013	0,55	0,52

1

2

0,26%

32

0,53% (

0,27% 0,57%).

3.5.

, %:

10 - 0,26 (0,28)*;

12 18 - 0,30 (0,32)*;

20 28 - 0,35 (0,37)*;

28 - 0,40 (0,42)*;

*

3.6

3.7.

3.8.

3.9.

(.)

52544.

3.10.

52544

7.

4

4.1

-

52544

7

4.1.1

4.1.2.

1)

2)

4.1.3

5

5.1

-

52544,

12004

7

:

5.1.1

32

5.1.2

3

8

()

$8 - 0,5L_r$

1

$8 - (-1)$

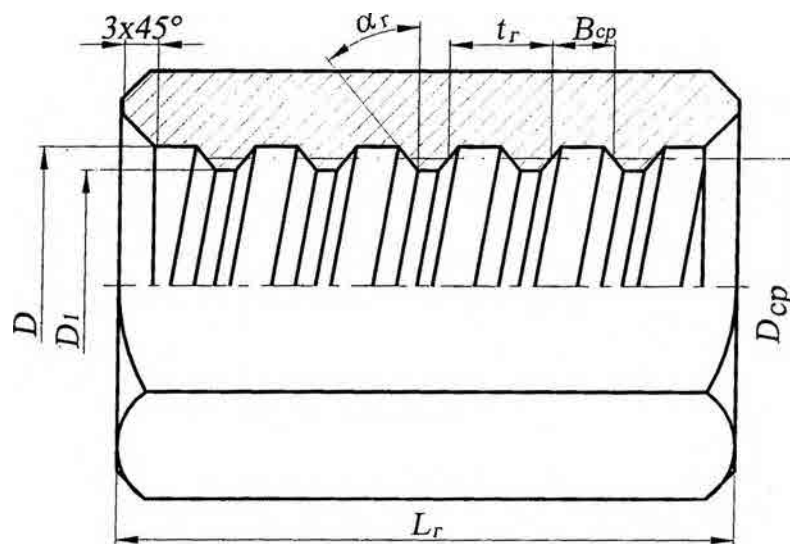

3 -

8 -

, d _H	Di		D	D _{Cp}				τ		L _r
	-	-		-	-	-	-			
15	15,3	+0,2 -0,0	18,5	16,9	+0,02 -0,0	4,5	+0,2 -0,0	10,0	40	100
16	16,0		19,7	17,9		4,3		9,0		90
18	18,0		22,0	20,0		4,7		10,0		100
20	19,9		24,1	22,0		5,4		11,0		110
22	22,0	26,4	24,2	5,7		12,0		120		
25	25,1	29,7	27,4	6,6		14,0		140		
26,5	27,1	+0,3 -0,0	31,7	29,4		6,3		13,0	130	
28	28,0		33,2	30,6		6,4		15,0	45	150
32	31,9		37,5	34,7		8,2		17,0		170
36	35,8		42,0	38,9		8,7		18,0		180
40	39,6		46,8	43,2	9,2	20,0	200			

6

6.1

52544

7

6.1.1

52544

6.1.2.

« 01/11? _____ 2006

A handwritten signature in black ink, appearing to be the name 'Иванов' (Ivanov) written in a cursive style.

()

12004-81 52544-2006 7-93	5.1, 1.3, 2.2.1, 2.3, 3.4, 3.9, 3.10, 4.1, 5.1, 6.1, 6.1.1, 1.3, 2.3, 3.10, 4.1, 5.1, 6.1

()

.1

. 1.1

() -

. 1.2

(,) -

. 1.3

()

(,).

4.1.2.

. 1.4

(

)

-

;

-

;

-

.

(

)

()

().

. 1.5

-

()

.2

()

.2.1

.2.2

()

(),

.1.

.1 -

1	-	16, 18, 20, 22, 25, 28		32, 36, 40
	,	16 (18); 25(28)		36 (40)
2	-	6,8,10	12,14,16,18,20,22,25,28	32,36,40,45,50, 55, 60
	,	6(8)	12 (14); 25 (28)	32 (36); 50(60)

.2.3

-

2.

.2

		-	-	
1.	(. .), §5	3	15	12004
2.	6 _D	3	6	3
3.	1	3	6	12004
4.		3	6	5
5.		2	6	5
			52544	
6.		1	3	5

.2.4

2, 5 6 .2
 (. .)
);
 1, 3 4 .2

.2.5.

.2.5

X - K S > X , (1)
 X - (1, 3 4 -
 .2);
 X - (1, 3 4 .2),
 1,2,3,4 5;
 S - ;
 95% (=0,95) 90%
 (1- =0,90).

5	3,40	30	2,08
6	3,09	40	2,01
7	2,89	50	1,97
8	2,75	60	1,93
9	2,65	70	1,90
10	2,57	80	1,89
11	2,50	90	1,87
12	2,45	100	1,86
13	2,40	150	1,82
14	2,36	200	1,79
15	2,33	250	1,78
16	2,30	300	1,77
17	2,27	400	1,75
18	2,25	500	1,74
19	2,23 j	1000	1,71
20	2,21		1,64

.2.6

.2.2 - .2.5.

-
-
-
-

(,)

()

.3.1

()

.4.

.4

	-		
3	9	4	
3	9	6	'

.3.2.

- .2 :

- -6 ;

- .

09 3111
09 3211
09 3311

77.140.15
32



7 7~

2007 .

14-1-5254-2006

1

: 01.03.2008 .



2007 .



2007 .

04* ."-."V i»

« >

, 2007 .

x h h h 1, 2 < .

Handwritten signature and date

1 5.1.1 :

«5.1.1 32-60 -

< (2

5\$

14-1-5557-2007».

2 . 14-1-5557-2007 -

5.1.1.

« . . . »:

« Б » 4L 2007

.

.

. . .

(« . . . »)

105005, 2-
/ 777-93-91
:

,9/23

.04.2008 .

/ -5254

2008 .

09 3111
09 3211
09 3311

32

14-1-5254-2006

«

»

3.2. 5. «
: «400 » 400 ».

375

В.Т. Абабков

. 777-93-91